

Vertical Gas Turbine Pump: Gas turbine provides quick start for flood control

Vericor's vertical ASE40V Gas Turbine packs 3.0MW of pumping power into a small footprint

CHALLENGE

Provide quick-start, reliable power to flood control pump with limited floor space

SOLUTION

Install Vericor's ASE40V Gas Turbine on top of a vertical pump

RESULTS

High power pumping with variable power turbine speeds capable of emptying a backyard pool in less than 4 seconds

OVERVIEW

The high volume of flood water produced by typhoons quickly fills low-lying areas and rivers in limited space areas of Japan. The local municipalities identified a need for a fast starting and high volume pumping system to quickly and reliably remove the flood waters from the affected areas. The limited available space in certain highly developed regions of Japan required a pump design that occupied a very small footprint, yet provided sufficient pumping power to remove the deluge of water from typhoons.

Vericor's packager in Japan designed an effective solution and installed several vertical pump packages using the Vericor ASE40V Gas Turbine.

The ASE40V engine is capable of starting from stop to full load in less than one minute and can switch fuels from gas to liquid on the fly, giving remarkable flexibility to the operators to mitigate unknown power and fuel outages in this critical application.

Aichi, Japan



The ASE40V gas turbine drives a vertical pump to quickly remove flood waters during a typhoon.



Case Study details and the benefit of an aeroderivative gas turbine

The customer's vertical pump design required a wide range of gas turbine power capabilities that were defined for each specific application. Applications range from flow rates of 825 cubic meters per minute (181,475 gpm) at a discharge head of 12.6 meters (41.3 feet) to flow rates of 1800 cubic meters per minute (395,945 gpm) at a discharge head of 3.2 meters (10.5 feet). This flow rate is equivalent to emptying a typical backyard pool in less than 4 seconds.

The ability of the ASE40V to operate at various power turbine speeds, coupled with the dual shaft design, provides the versatility required to accommodate a wide range of pumping power requirements.

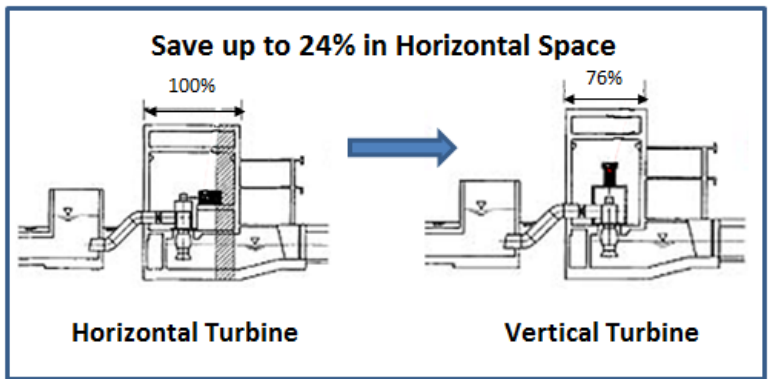

Space Savings for Vertical Gas Turbine Installation

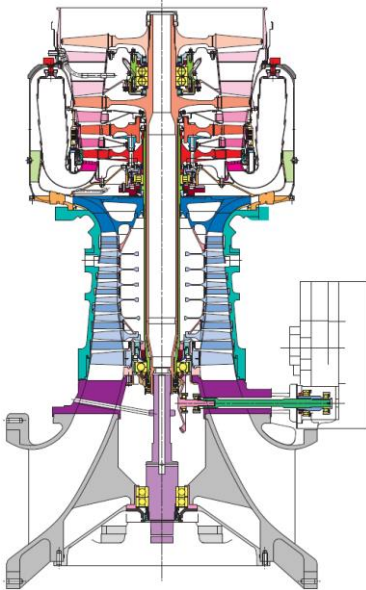

ASE40V Cross Section

The ASE40V gas turbine was selected as the best-fit to satisfy a small footprint and quick start requirement.

Vericor's ASE gas turbines are a proven aero-derivative design that are specifically configured for power generation and mechanical drive applications. Advantages of using these gas turbine systems for these applications are many:

- Compact size allows for easy on site installation and change out
- High operational readiness
- Fast cold start characteristics
- Low emissions and vibration
- Flexibility to efficiently burn a variety of fuels
- High reliability and low maintenance requirements

The modular nature of these engines allows for easy inspections on site. This ease of care approach simplifies stocking of spares and lowers downtime and maintenance periods. Recommended maintenance cycles are 30,000 hours for a hot section overhaul and 60,000 hours for a major overhaul.